



Datolink Ltd

0811,Rujun Building, AV.Banxuegang,Bantian,Longgang district,Shenzhen,China 518129
Tel: 86-755-25263582 25263585 Fax: 86-755-28367056
Website: www.datocom.com

产 品 规 格 书

Product Specification Sheet

DTSB35(53)12L-CD20

RoHS Compliant 1.25G 1310/1550nm(1550/1310nm) 20KM Transceiver



PRODUCT FEATURES

- Up to 1.25Gb/s data links
- FP laser transmitter for DTSB35(53)12L-CD20
- DFB laser transmitter for DTSB53(35)12L-CD20
- PIN photo-detector
- Up to 20km on 9/125µm SMF
- Hot-pluggable SFP footprint
- BIDI LC/UPC type pluggable optical interface
- Low power dissipation
- Metal enclosure, for lower EMI
- RoHS compliant and lead-free
- Single +3.3V power supply
- Support Digital Diagnostic Monitoring interface
- Compliant with SFF-8472
- Case operating temperature
 - Commercial: 0 °C to +70 °C**
 - Extended: -10 °C to +80 °C**
 - Industrial: -40 °C to +85 °C**

APPLICATIONS

- Switch to Switch Interface
- Fast Ethernet
- Switched Backplane Applications
- Router/Server Interface
- Other Optical Links

STANDARD

- SFP+ MSA Compliant
- SFF-8472 reversion 9.5 compliant
- IEEE802.3-2005 compliant
- Telcordia GR-468-CORE compliant
- FCC 47 CFR Part 15, Class B compliant
- FDA 21 CFR 1040.10 and 1040.11, class1 compliant
- RoHS compliant

PRODUCT DESCRIPTIONS

- Datocom DTSB35 (53) 12L-CD20 optical transceivers are designed for optical interfaces for data communications with
- single mode fiber (SMF). The transceiver designs are optimized for high performance and cost effective to supply customers the best solutions for telecom applications.

FUNCTIONAL DIAGRAM

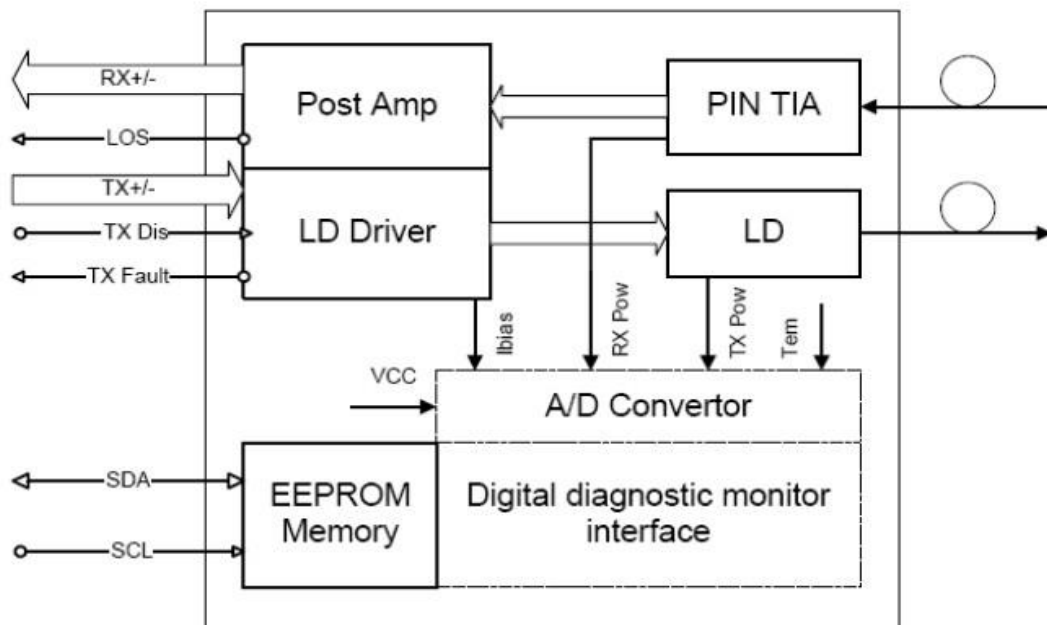

Ordering information

Product part Number	Data Rate (Gbps)	Media	Wavelength (nm)	Transmission Distance(km)	Temperature Range (Tcase) (°C)	
DTSB35 (53) 12L-CD20	1.25	Single mode fiber	1310/1550(1550/1310)	20	0~70	commercial
DTSB35 (53) 12L-ED20	1.25	Single mode fiber	1310/1550(1550/1310)	20	-10~80	extended
DTSB35 (53) 12L-ID20	1.25	Single mode fiber	1310/1550(1550/1310)	20	-45~85	industrial

ABSOLUTE MAXIMUM RATINGS

Parameter	Symbol	Min.	Max.	Unit	Note
Supply Voltage	V _{cc}	-0.5	4.0	V	
Storage Temperature		-40	85	°C	
Relative Humidity		5	95	%	

Note: Stress in excess of the maximum absolute ratings can cause permanent damage to the module

GENERAL OPERATING CHARACTERISTICS

Parameter	Symbol	Min.	Typ	Max.	Unit	Note
Data Rate			1.25		Gb/s	
Supply Voltage	V _{cc}	3.13	3.3	3.47	V	
Supply Current	I _{ccs}			280	mA	
Operating Case Temp.	T _c	0		70	°C	DTSB35 (53) 12L-CD20
		-10		80	°C	DTSB35 (53) 12L-ED20
		-40		85	°C	DTSB35 (53) 12L-ID20

ELECTRICAL INPUT/OUTPUT CHARACTERISTICS

● Transmitter

Parameter	Symbol	Min.	Typ	Max.	Unit	Note
Diff. input voltage swing		120		820	mVpp	1
Tx Disable input	H	V _{IH}	2.0		V _{cc} +0.3	V
	L	V _{IL}	0		0.8	
Tx Fault output	H	V _{OH}	2.0		V _{cc} +0.3	V
	L	V _{OL}	0		0.8	
Input Diff. Impedance	Z _{in}		100		Ω	

● Receiver

Parameter	Symbol	Min.	Typ	Max.	Unit	Note
Diff. output voltage swing		340	650	800	mVpp	3
Rx LOS Output	H	V _{OH}	2.0		V _{cc} +0.3	V
	L	V _{OL}	0		0.8	

Note 1) TD+/- are internally AC coupled with 100Ω differential termination inside the module.

Note 2) Tx Fault and Rx LOS are open collector outputs, which should be pulled up with 4.7k to 10k Ω resistors on the host board. Pull up voltage between 2.0V and Vcc+0.3V.
 Note 3) RD+/- outputs are internally AC coupled, and should be terminated with 100 Ω (differential) at the user SERDES.

OPTICAL CHARACTERISTICS

- Transmitter

Parameter	Symbol	Min.	Typ	Max.	Unit	Note
Operating Wavelength	λ_C	1270	1310	1360	nm	
		1500	1550	1570		
Ave. output power (Enabled)	Po	-8		-4	dBm	1
Extinction Ratio	ER	9			dB	1
RMS spectral width	$\Delta\lambda$			3.5	nm	
Rise/Fall time (20%~80%)	Tr/Tf			0.26	ps	2
Output Eye Mask	Telcordia GR-253-CORE and ITU-T G.957 compatible					

Note (1): Measure at 2⁷-1 NRZ PRBS pattern

Note (2): Transmitter eye mask definition

- Receiver

Parameter	Symbol	Min.	Typ	Max.	Unit	Note
Operating Wavelength		1530	1550	1570	nm	
		1270	1310	1360		
Sensitivity	Psen			-25	dBm	3
Min. overload	Pimax	-3			dBm	
LOS Assert	Pa	-35			dBm	
LOS De-assert	Pd			-26	dBm	
LOS Hysteresis	Pd-Pa	0.5		6	dB	

Note 1) Measured at 10.3125b/s with PRBS 2³¹ - 1 NRZ test pattern.

Note 2) 20%~80%

Note 3) Under the ER worst case, measured at 10.3125 Gb/s with PRBS 2³¹ - 1 NRZ test pattern for BER < 1x10⁻¹²

Digital Diagnostic Functions

Datocom DTSB35(53)12L-CD20 transceivers support the 2-wire serial communication protocol as defined in the SFP MSA. It is very closely related to the E2PROM defined in the GBIC standard, with the same electrical specifications.

The standard SFP serial ID provides access to identification information that describes the transceiver's capabilities, standard interfaces, manufacturer, and other information.

Additionally, Datacom SFP transceivers provide a unique enhanced digital diagnostic monitoring interface, which allows real-time access to device operating parameters such as transceiver temperature, laser bias current, transmitted optical power, received optical power and transceiver supply voltage. It also defines a sophisticated system of alarm and warning flags, which alerts end-users when particular operating parameters are outside of a factory set normal range.

The SFP MSA defines a 256-byte memory map in E2PROM that is accessible over a 2-wire serial interface at the 8bit address 1010000X (A0h). The digital diagnostic monitoring interface makes use of the 8 bit address 1010001X (A2h), so the originally defined serial ID memory map remains unchanged. The interface is identical to, and is thus fully backward compatible with both the GBIC Specification and the SFP Multi Source Agreement.

The operating and diagnostics information is monitored and reported by a Digital Diagnostics Transceiver Controller (DDTC) inside the transceiver, which is accessed through a 2-wire serial interface. When the serial protocol is activated, the serial clock signal (SCL, Mod Def 1) is generated by the host. The positive edge clocks data into the SFP transceiver into those segments of the E2PROM that are not write-protected. The negative edge clocks data from the SFP transceiver. The serial data signal (SDA, Mod Def 2) is bi-directional for serial data transfer. The host uses SDA in conjunction with SCL to mark the start and end of serial protocol activation. The memories are organized as a series of 8-bit data words that can be addressed individually or sequentially.

Digital diagnostics for the DTSB35(53)12L-CD20 are Internally calibrated by default.

Pin Definitions and Functions

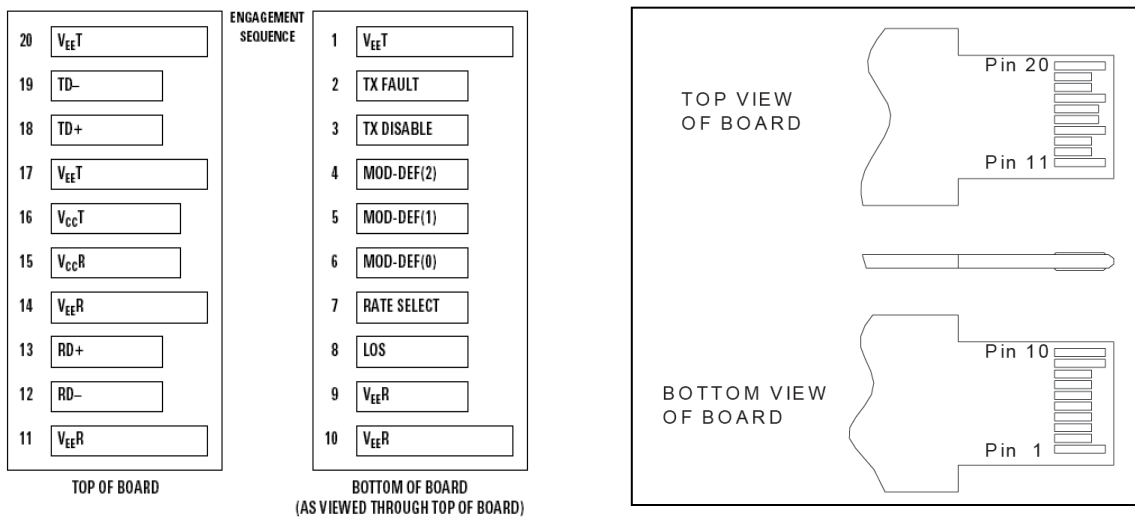

PIN #	Name	Function	Notes
1	VeeT	Module transmitter ground	Note 1
2	Tx Fault	Module transmitter fault	Note 2
3	Tx Disable	Transmitter Disable; Turns off transmitter laser output	Note 3
4	SDL	2 wire serial interface data input/output (SDA)	
5	SCL	2 wire serial interface clock input (SCL)	
6	MOD-ABS	Module Absent, connect to VeeR or VeeT in the module	Note 2
7	RS0	Rate select0, optionally control SFP+ receiver. When high, input data rate >4.5Gb/s; when low, input data rate <=4.5Gb/s	
8	LOS	Receiver Loss of Signal Indication	Note 4
9	RS1	Rate select1, optionally control SFP+ transmitter. When high, input data rate >4.5Gb/s; when low, input data rate <=4.5Gb/s	
10	VeeR	Module receiver ground	Note 1
11	VeeR	Module receiver ground	Note 1
12	RD-	Receiver inverted data out put	
13	RD+	Receiver non-inverted data out put	
14	VeeR	Module receiver ground	Note 1
15	VccR	Module receiver 3.3V supply	
16	VccT	Module transmitter 3.3V supply	
17	VeeT	Module transmitter ground	Note 1
18	TD+	Transmitter inverted data out put	
19	TD-	Transmitter non-inverted data out put	
20	VeeT	Module transmitter ground	Note 1

Note 1) The module ground pins shall be isolated from the module case.

Note 2) This pin is an open collector/drain output pin and shall be pulled up with 4.7K-10Kohms to Host_Vcc on the host board.

Note 3) This pin shall be pulled up with 4.7K-10Kohms to VccT in the module.

Note 4) This pin is an open collector/drain output pin and shall be pulled up with 4.7K-10Kohms to Host_Vcc on the host board. In FC designated as RX_LOS, in SONET designated as LOS, and in Ethernet designated at Signal Detect.

TYPICAL INTERFACE CIRCUIT

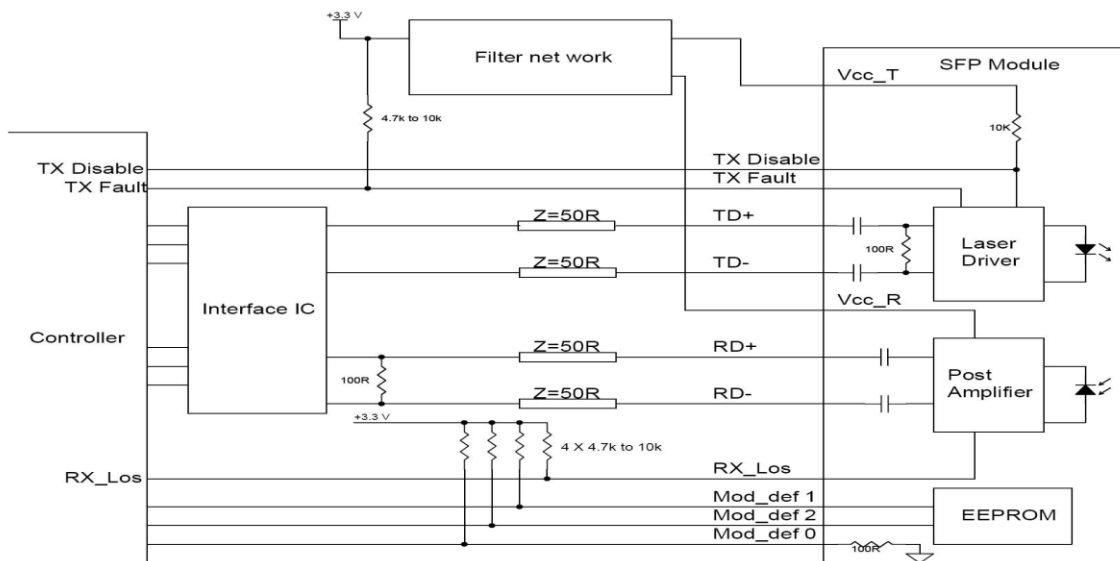

Recommended power supply filter

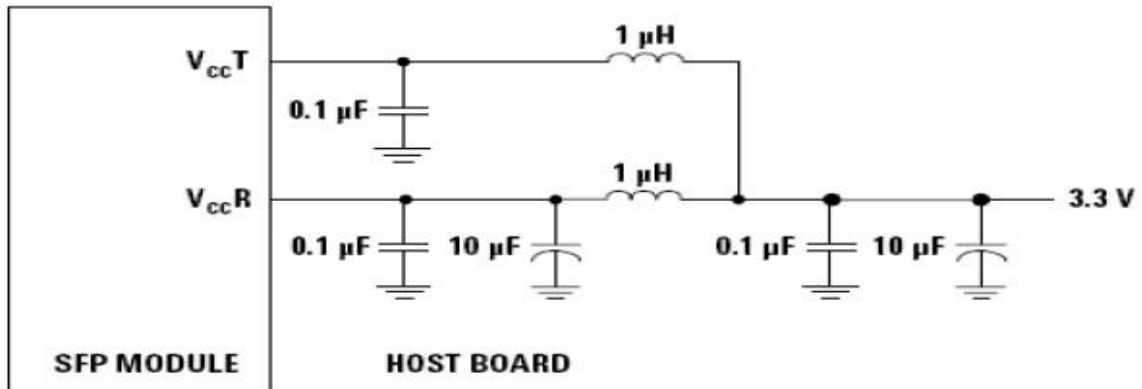

Note: Inductors with DC resistance of less than 1Ω should be used in order to maintain the required voltage at the SFP input pin with 3.3V supply voltage. When the recommended supply filtering network is used, hot plugging of the SFP transceiver module will result in an inrush current of no more than 30 mA greater than the steady state value

PACKAGE DIMENSIONS

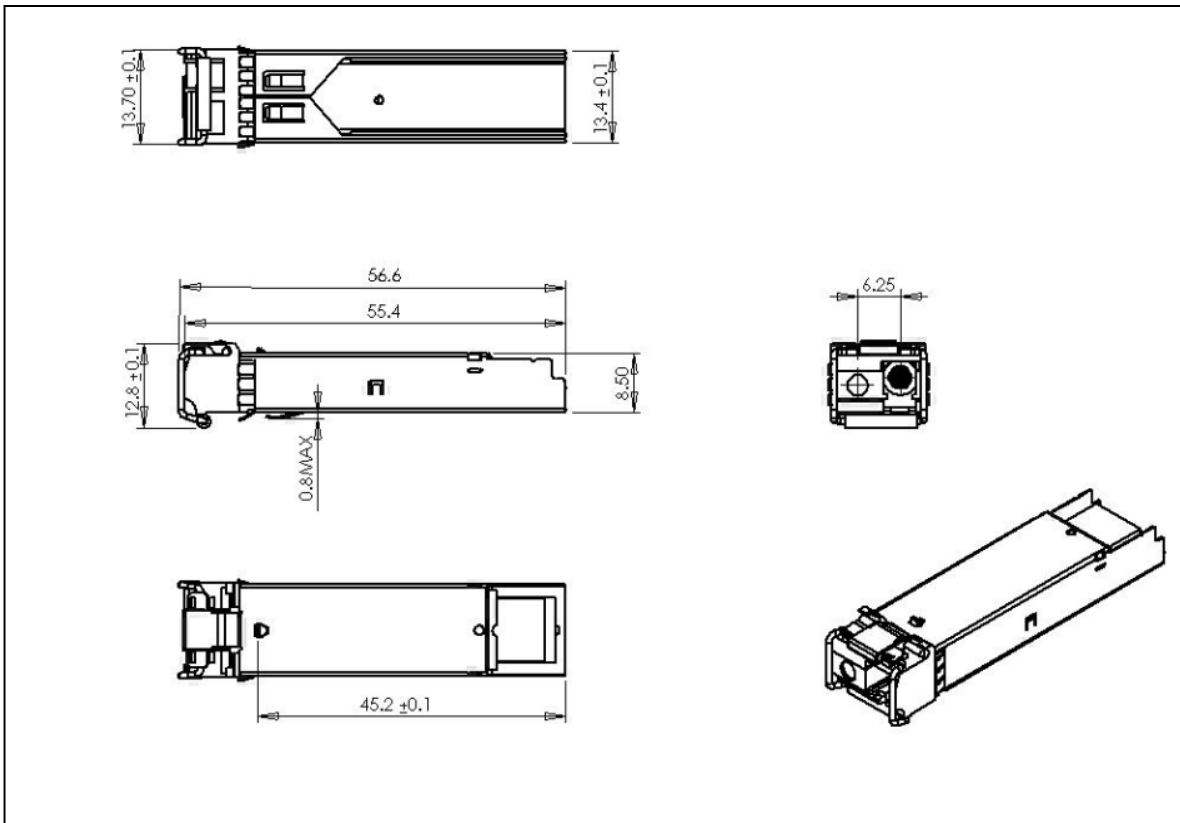

FOR MORE INFORMATION

DATOLINK Ltd

Add: 0811,Rujun Building, AV.Banxuegang, Bantian,
Longgang District,Shenzhen,China 518129

Tel: 86-755-25263582 25263585

Fax:86-755-28367056

Email: sales@datolink.com

Website:www.datocom.com